

T4360G, T6360D, T6360E Line Voltage Thermostat

PRODUCT DATA

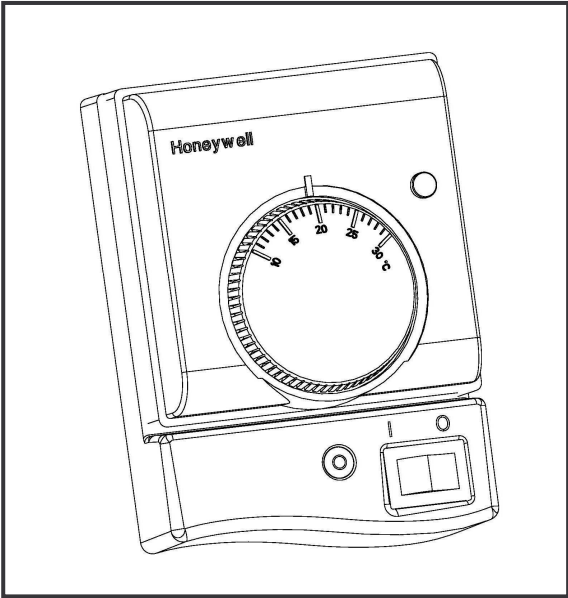

FEATURES

- Models available for heat only, cool only and heat pump systems.
- Fan models for air circulation.
- Three-speed fan model to improve circulation and temperature control.
- 16A model available for direct switching of high current loads.
- Indicator lamp on all models.

APPLICATION

The T4360G thermostat with on/off switch provides control of 240Vac heat only systems with a maximum current of 16A.

The T6360D thermostat with on/off switch provides control of 240Vac cool only systems.

The T6360E thermostats provide control of 240Vac heat pump systems with or without fan control.

Contents

APPLICATION 1
FEATURES..... 1
SPECIFICATIONS..... 2
INSTALLATION 3
OPERATION..... 5
ACCESSORIES..... 5
WIRING DIAGRAMS 6

SPECIFICATIONS

IMPORTANT

The specifications given in this publication do not include normal manufacturing tolerances. Therefore, this unit might not exactly match the listed specifications. This product is tested and calibrated under closely controlled conditions, and some minor differences in performance can be expected if those conditions are changed.

Thermostat Model

T4360/T6360 Thermostats provide features listed in Table1.

Table 1. Thermostat Features.

Model	System Selection	Fan Selection	Comments
T4360G1006	On-Off	None	Heat only
T6360D1008	On-Off	None	Cool only
T6360E1005	Heat-Off-Cool	None	Heat pump
T6360E1013	Heat-Off-Cool	Cont-Auto	Heat Pump
T6360E1021	Heat-Off-Cool	Lo-Med-Hi	Heat Pump

Dimensions:

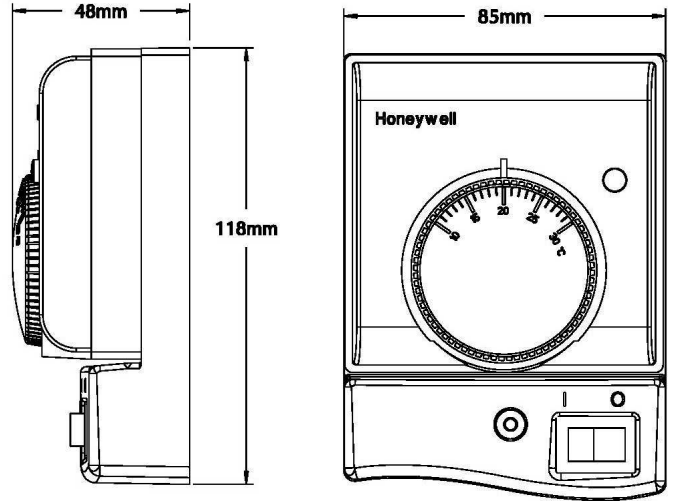

Electrical Rating (Nominal Range):

220-240Vac, 50/60 Hz

T4360G: 16A

T6360D: 10(3) A

T6360E: 10(3) A

Batteries:

No Batteries required.

Temperature:

Temperature Range: 10-30 °C.

Operating Ambient Temperature: 0 °C to 40 °C.

Storage Temperature: -20 °C to 50 °C.

Humidity Ratings:

0-90% RH, non condensing.

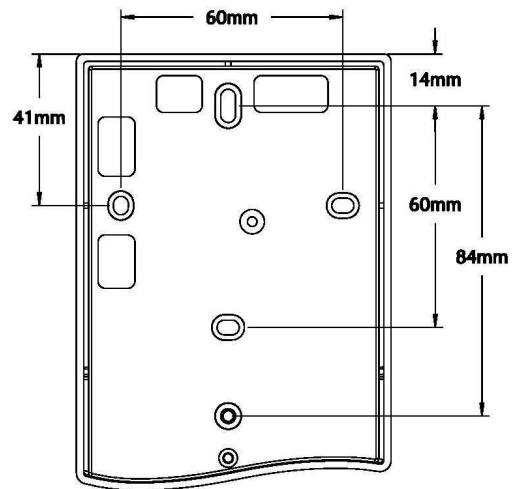

INSTALLATION

When Installing this Product...

1. Read these instructions carefully. Failure to follow the instructions can damage the product or cause a hazardous condition.
2. Check the ratings given in the instructions and on the product to make sure the product is suitable for your application.
3. Installer must be a trained, experienced service technician.
4. After completing installation, use these instructions to check out the product operation.

Location

Install the thermostat about 5 ft (1.5m) above the floor in an area with good air circulation at average temperature. See Fig. 1.

Do not install the thermostat where it can be affected by:

- Drafts, or dead spots behind doors and in corners.
- Hot or cold air from ducts.
- Radiant heat from sun or appliances.
- concealed pipes and chimneys.
- unheated (uncooled) areas such as an outside wall behind the thermostat.

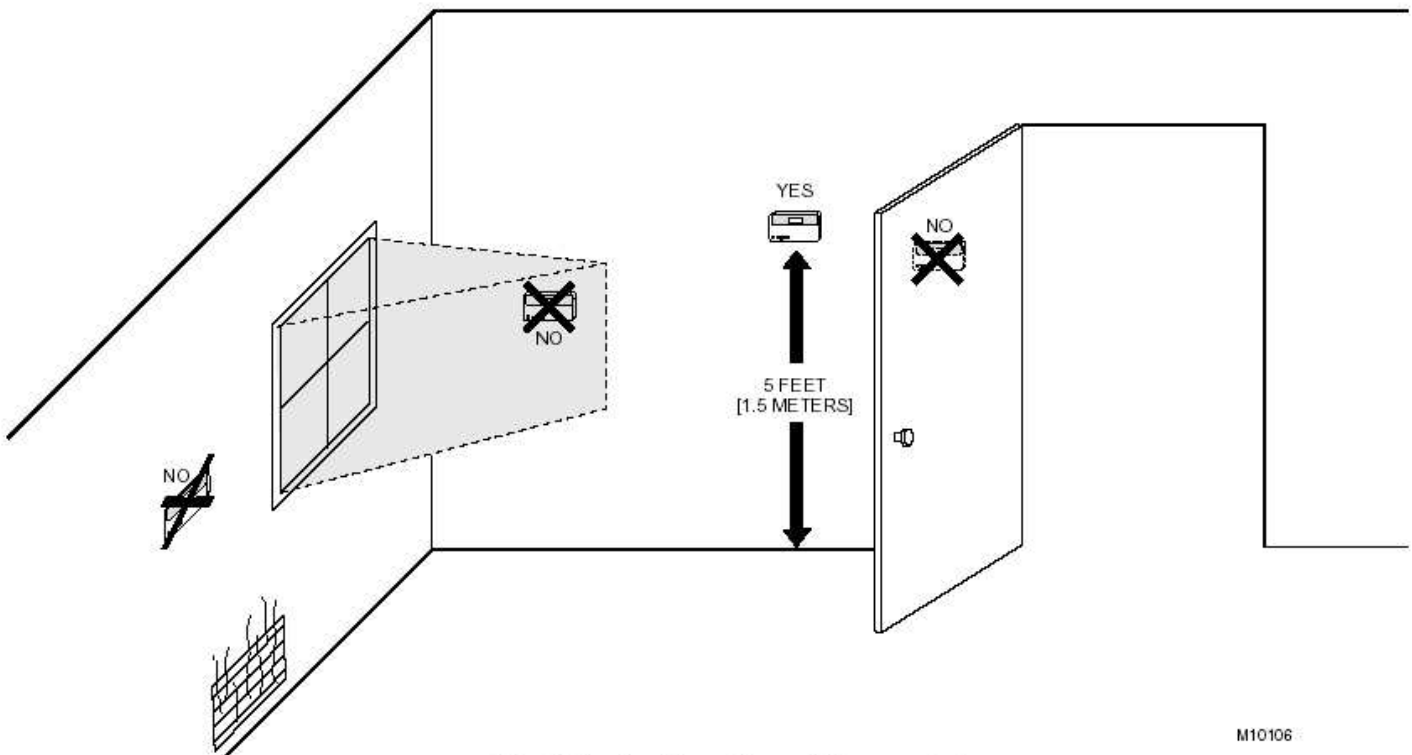

Fig. 1. Typical location of thermostat.

M10106

Sub base Installation

The thermostat can be mounted horizontally or vertically on the wall or a wall plate/box. Refer to Figs 2 and 3.

1. Position and level the sub base (for appearance only). The thermostat will function properly even when not level.
2. Use a pencil to mark the mounting holes.
3. Remove the sub base from the wall and drill two in the wall as marked. Gently tap anchors into the drilled holes until flush with the wall.
4. Position the sub base over the holes, pulling wires through the wiring opening.
5. Loosely insert the mounting screws into the holes.
6. Tighten mounting screws.

Wiring

All wiring must comply with local electrical codes and ordinances. Refer to Figs. 4 - 8 for typical wiring. A number code is located near each terminal for identification.



CAUTION

Disconnect power before wiring to prevent electrical shock or equipment damage.

1. Loosen the terminal screws on the subbase and connect the fan wires (T6360E fan models only).
2. Remove the cover from the thermostat and attach thermostat base to subbase.
3. Loosen the terminal screws on the thermostat base and connect the system wires (all models).
4. Replace thermostat cover.

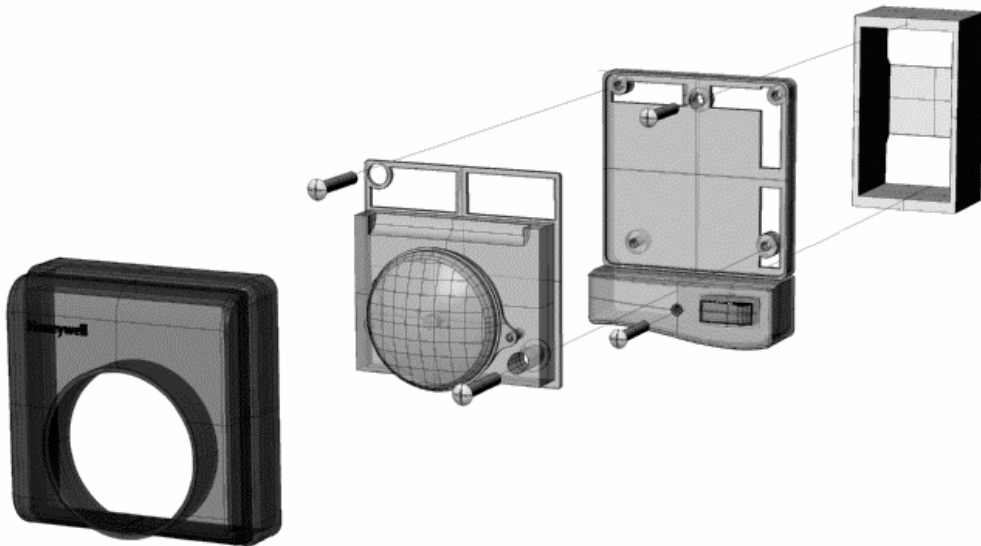

Fig 2: Vertical Installation diagram



Fig 3: Horizontal Installation diagram

OPERATION

Sensing Element

The thermostat sensing element comprises two circular, flexible metal plates welded together at the rims encapsulating a liquid whose pressure changes greatly in response to small variations in temperature. In effect, this dual diaphragm forms a 'bellows' which expands/contracts in sympathy with the ambient temperature changes – this movement serving to operate a snap acting switch rated to control the heating or cooling circuit.

Switches

The On/Off switch provides a means of manually isolating the mains input to the thermostat to provide a positive off feature.

The Heat/Off/Cool switch provides a means of selecting the thermostat to heat or to Cool and also to provide a positive off. When the switch is selected in the heat position the thermostat will activate on a temperature fall, when the switch is selected to cool, the thermostat will activate on a temperature rise.

The fan switches provide a means to control the system fan. The Cont/Auto switch allows continuous or auto control of the fan. When the switch is selected to Auto the fan operates with the equipment. The Lo/Med/Hi fan switch allows three fan speeds to be selected.

Indicator Lamp

All models have an indicator lamp. On T4360G the lamp indicates that the heating equipment is being switched on.

The lamp on the T6360D indicates that the cooling equipment is being switched by the thermostat. On the T6360E models the lamp indicates when the compressor is being switched on.

ACCESSORIES

No	Accessory	Part Number	Suit	Notes
1	Range Stops	F42006646-001	All models	
2	Replacement Dial	R42006961-001	All models	Celsius markings
3	Tamperproof Cover	F42007110-001	All models	Only covers dial, not switches

Wiring

All wiring must comply with local electrical codes and ordinances. Refer to Figs. 4 - 8 for typical wiring. A number code is located near each terminal for identification.

1. Loosen the terminal screws on the subbase and connect the fan wires (T6360E fan models only).
2. Remove the cover from the thermostat and attach thermostat base to subbase.
3. Loosen the terminal screws on the thermostat base and connect the system wires (all models).
4. Replace thermostat cover.



CAUTION

Disconnect power before wiring to prevent electrical shock or equipment damage.

WIRING DIAGRAMS

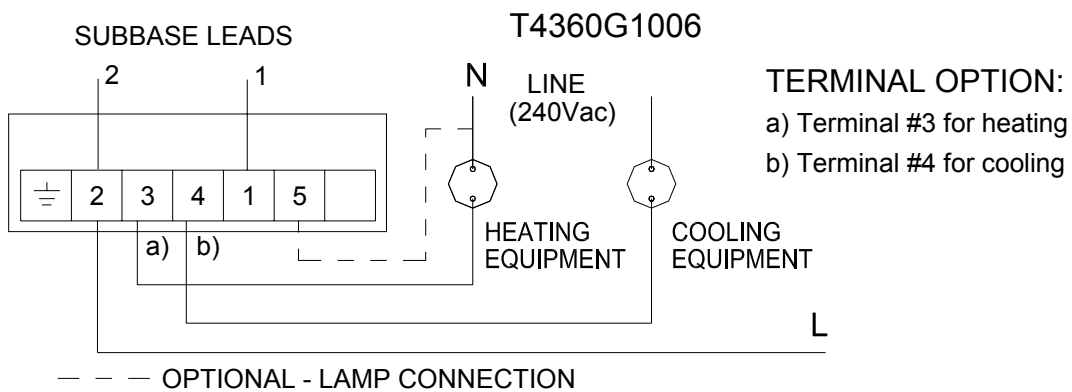

Fig 4: T4360G1006 (Heat or Cool, light operates on temp fall) wiring diagram

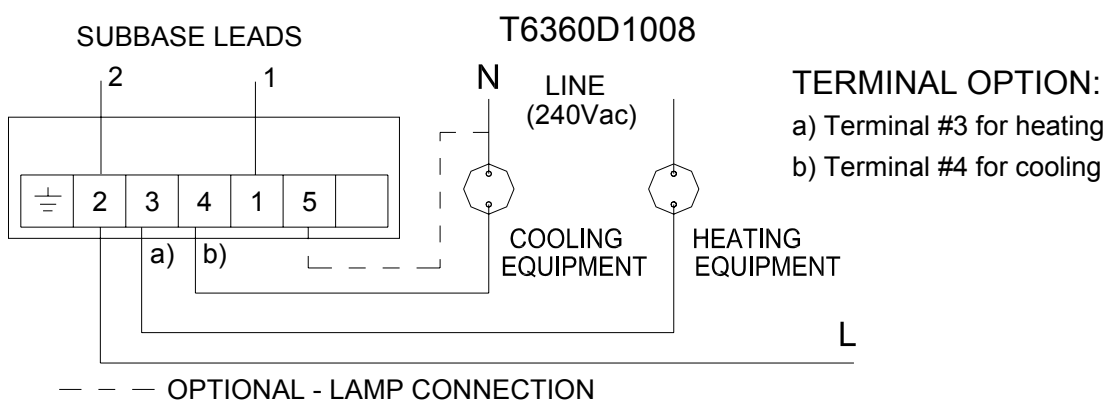

Fig 5: T6360D1008 (Cool or Heat, light operates on temp rise) wiring diagram

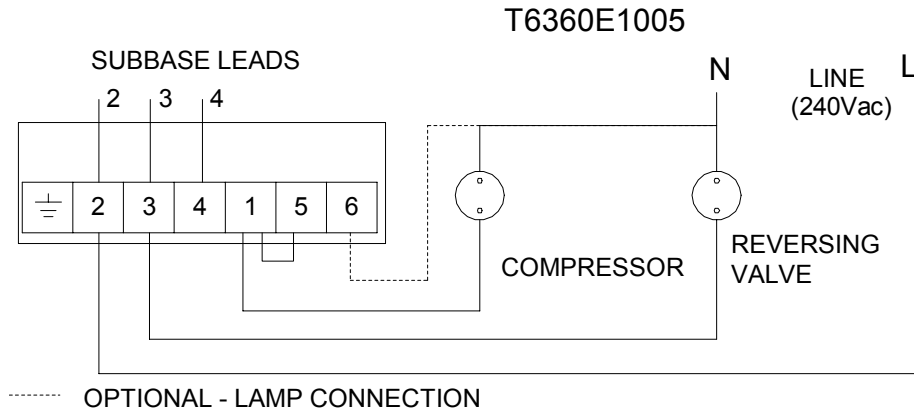

Fig 6: T6360E1005 (Heat Pump Heat/Off/Cool) wiring diagram

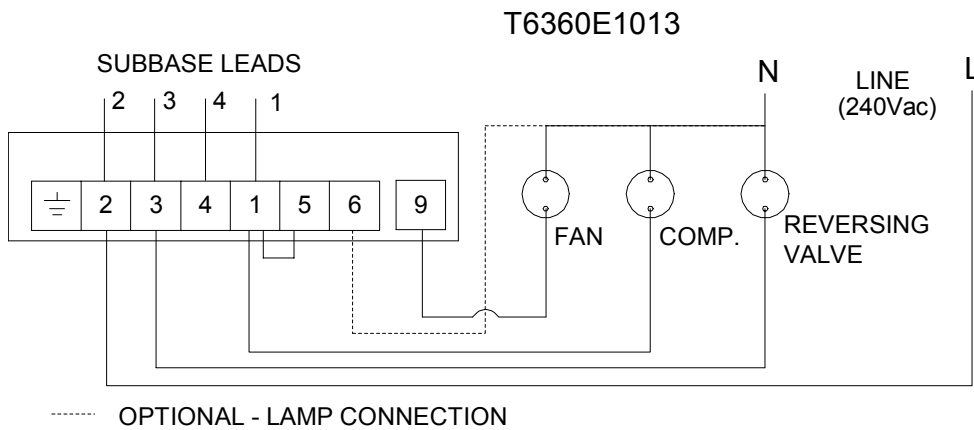

Fig 7: T6360E1013 (Heat Pump Heat/Off/Cool Cont/Auto Fan) wiring diagram

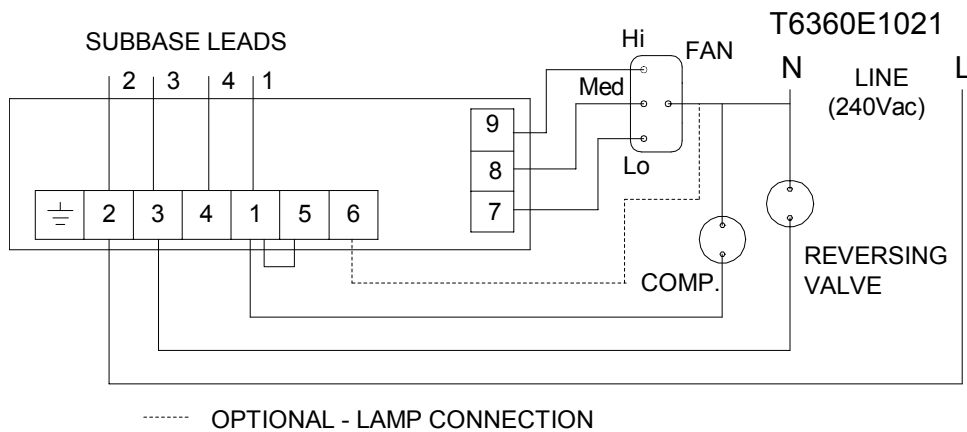

Fig 8: T6360E1021 (Heat Pump Heat/Off/Cool Lo/Med/Hi Fan) wiring diagram

Honeywell

Environmental Controls

Honeywell
 2 Richardson Place
 North Ryde NSW 2113